

Goodmans

MICRO 1103 MICRO SYSTEM CD FM/MW RADIO

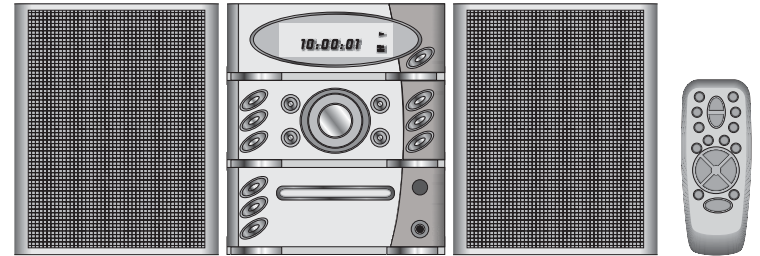

INSTRUCTION MANUAL

Before operating this unit,
please read this Owners manual carefully.

Goodmans product information helpline:

0870 873 0080

INTRODUCTION

This instruction manual is important to you. Please read it. In a short time it shows exactly how to connect, operate, and adjust this unit for best performance.

It can save you money. It shows simple things to do and check before you call for help and save the cost of unnecessary service or call out charge.

Table of contents.....	1
Important Notes.....	2
Important Safeguards.....	3-4
Location of Controls.....	5-6
Display.....	7
Remote Control.....	8
Speaker Cord Connection.....	9
Switching the unit on and off.....	9
Setting the Clock.....	10
Compact Discs.....	11
Compact Disc Operation.....	11
Operation/Remain Function.....	13
Tuner Operation.....	14
Timer Operation.....	15
Sleep/Preset equalizer/Mute.....	16
Connecting an External Audio Source.....	16
Troubleshooting Guide.....	17
Technical Specifications.....	18

Save the carton and packing material; they will be useful if you ever have to transport the unit.

Pack contents:
1 x main unit
1 x remote control
2 x loudspeakers
1 x owner's manual

Please retain all packaging material for future transportation of the unit or in the unlikely event that the unit needs to be returned for service.

IMPORTANT NOTES

Your hearing is very important to you and to us so please take care when operating this equipment. It is strongly recommended that you follow the listed guidelines in order to prevent possible damage or loss of hearing.

Establish a safe sound level

Over time your hearing will adapt to continuous loud sounds and will give the impression that the volume has in fact been reduced. What seems normal to you may in fact be harmful. To guard against this before your hearing adapts set the volume at a low level.

Once you have established a comfortable listening level do not increase the sound level further. The following list of typical sound levels may assist you in recognizing just how loud you have set the volume level.

Decibel

Level dB example

30dB quiet library, soft whisper.

40dB Living room, fridge freezer bedroom away from traffic.

50dB normal conversation, quiet office, light traffic.

60dB Electric sewing machine.

70dB Vacuum cleaner, hair dryer, noisy restaurant.

The following noise can be harmful under constant exposure

80dB Average city traffic, alarm clock buzzer at 2 feet, food mixer.

90dB Motorcycle, heavy goods vehicle, petrol lawn mower.

100dB Pneumatic drill, chain saw, garbage truck, discotec/night-club.

120dB Rock band concert, thunderclap .

Permanent loss of hearing

140dB Threshold of pain gunshot 2 feet away.

180dB Rocket launching pad.

IMPORTANT SAFEGUARDS

PRE FITTED MAINS PLUGS

For your convenience a mains plug has been fitted to this appliance. For your safety please observe the following information.

1. Should the fuse in the plug fail remove the plug from the wall socket and replace the fuse with a 3 Amp ASTA approved to BS 1362 fuse.
 2. Never use the plug without the fuse cover fitted. Replacement fuse covers are available from your dealer or most electrical retail outlets.
 3. If the mains plug is cut off the cable, rewire the replacement plug in accordance with instruction give in this manual.
 4. CAUTION: Under no circumstances should the discarded plug be inserted into the mains socket. To prevent a shock hazard carefully dispose of the discarded plug. Do not leave the plug lying around where children might see it.
- WARNING: To prevent fire or shock hazard do not expose this unit to rain or moisture.

CAUTION: DANGEROUS VOLTAGES EXIST INSIDE THIS UNIT. DO NOT REMOVE COVER (OR BACK). NO USER SERVICEABLE PARTS INSIDE REFER SERVICING TO QUALIFIED SERVICE PERSONNEL. DISCONNECT FROM MAINS SUPPLY WHEN NOT IN USE.

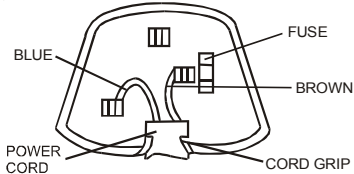

This wires in this mains lead are coloured in accordance with the following wiring codes:
Blue.....Neutral
Brown.....Live
This wires in this mains lead must be connected to the terminals in the plug as follows:
Blue Wire.....N or Black
Brown Wire.....L or Red
Only a 3 Amp fuse should be fitted in the plug or a 5 Amp fuse at the distribution board.

WARNING: UNDER NO CIRCUMSTANCES MUST THE LIVE OR NEUTRAL WIRES BE CONNECTED TO THE EARTH TERMINAL IN A 3- PIN MAINS PLUG.



This symbol means that this unit is double insulated. An earth connection is not required.

CAUTION

CLASS 1 LASER PRODUCT

Use of contents or adjustments of performance of procedures other than those specified Herein may result in hazardous radiation exposure.

LASER SAFETY

This unit employs a laser, only qualified service personnel should attempt repair.



DANGER: INVISIBLE LASER RADIATION WHEN OPEN AND INTERLOCK FAILED OR DEFEATED. AVOID DIRECT EXPOSURE TO BEAM.

CAUTION: HAZARDOUS LASER RADIATION WHEN OPEN AND INTERLOCK DEFEATED.

SOME DO'S AND DON'T'S ON THE SAFE USE OF EQUIPMENT

This equipment has been designed and manufactured to meet European safety standards but like any electrical equipment, care must be taken if you are to obtain the best results and safety is to be assured.

Do read the operating instruction before you attempt to use the equipment. Do ensure that all electrical connections (including the mains plug, extension leads and interconnections between pieces of equipment) are properly made in accordance with the manufacture's instructions. Switch off and remove the mains plug when making or changing connections.

Do consult your dealer if you are ever in doubt of the installation, operation, or safety of your equipment.

Don't continue to operate the equipment if you are in any doubt about it working normally, or if it is damaged in any way—switch off, withdraw the mains plug and consult your dealer. Don't remove any fixed covers as this may expose DANGEROUS VOLTAGES. Don't leave equipment switched on when it is unattended unless it is specifically stated that it is designed for unattended operation or has a standby mode. Switch off using the switch on the equipment and made sure that your family knows how to do this, special arrangements may need to be made for infirm or handicapped people.

Don't listen to headphones at high volume, as such use can permanently damage your hearing.

Don't obstruct the ventilation of the equipment, for example with curtains or soft furnishings overheating will cause damage and shorten the life of the equipment.

Don't allow electrical equipment to be exposed to rain or moisture.

Above all

- Never let anyone, especially children, push anything into holes, slots or any other opening, as this could result in a fatal electric shock.
- Never guess or take chances with electrical equipment of any kind.
- It is better to safe than sorry.

WARNING: TO REDUCE THE RISK OF FIRE OR ELECTRIC SHOCK. DO NOT EXPOSE THIS APPLIANCE TO RAIN MOISRURE, DANGEROUS HIGH VOLTAGES ARE PRESENT INSIDE THE ENCLOSURE, DO NOT OPEN THE CABINET REFER SERVICING TO QUALIFIED PERSONNEL ONLY.

LOCATION OF CONTROLS

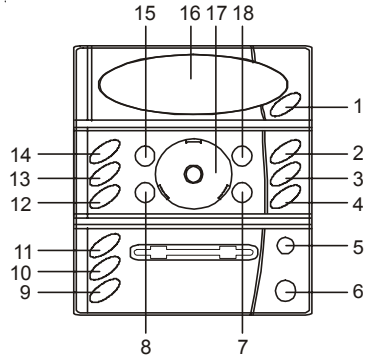

1. **POWER Key**
 - Press to turn the power ON/ Stand-by.
2. **CD Key**
 - Select the CD source.
3. **TUNER Key**
 - Select the Tuner source.
4. **AUX Key**
5. **REMOTE SENSOR**
6. **PHONES Jack**
 - Connection for headphones.
7. **DOWN/REW Key**
 - In the Radio mode: search down the current waveband.
 - In the CD mode: return to the start of a track, select a previous track or backwards search for a passage during play.
 - In the Clock/Timer mode: adjust the time.
8. **STOP/BAND Key**
 - In the CD mode: stop playback of the compact disc or clear program.
 - In the Radio mode: change the waveband.
9. **SLEEP/TIMER Key**
 - Activate or deactivate timer or sleep.
10. **RANDOM Key**
 - In the CD mode: play tracks on the CD in random order.
11. **PRESET EQUALIZER Key (EQ)**
 - Add digital sound effect to Audio output using one of these styles: CLASSIC/ POP/ ROCK.
12. **MEMORY/CLOCK ADJUSTMENT Key (MEMORY/CLK-ADJ)**
 - In the Radio mode: cycle through the current radio presets.
 - In the CD mode: program CD to play tracks in a specific order.
 - In the clock mode: set clock or timer.
13. **DISPLAY/REMAIN Key**
 - To Change the display.
14. **MUTE Key**
 - Mute the audio output.
15. **PLAY/PAUSE Key**
 - In the CD mode: start or pause playback.
16. **DISPLAY**
17. **VOLUME CONTROL KNOB**
 - Adjust the volume level.
18. **UP/FF Key**
 - In the Radio mode: search up the current waveband.
 - In the CD mode: return to the start of a track, select the next track or search forward for a passage during playback.
 - In the Clock/Timer mode: adjust the time.

19. AUX INPUT SOCKET

- For connection of external sound sources.

20. SPEAKER SOCKET

21. SELECTOR SWITCH (FM MODE/MONO STEREO)

22. AC POWER CORD

NOTE: CD DOOR WILL ONLY OPEN/CLOSE WHEN IN CD MODE

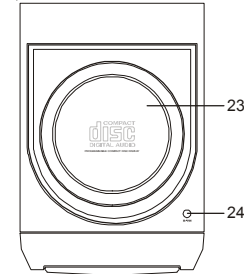

23. CD TRAY

24. OPEN Key

- For compact disc.

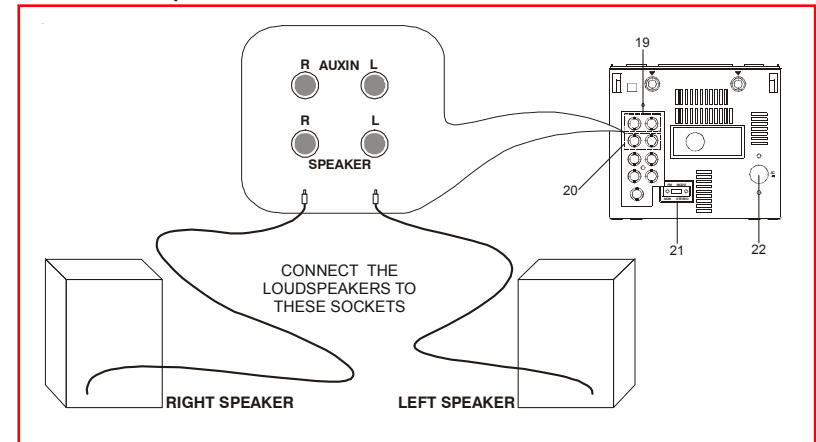

DISPLAY

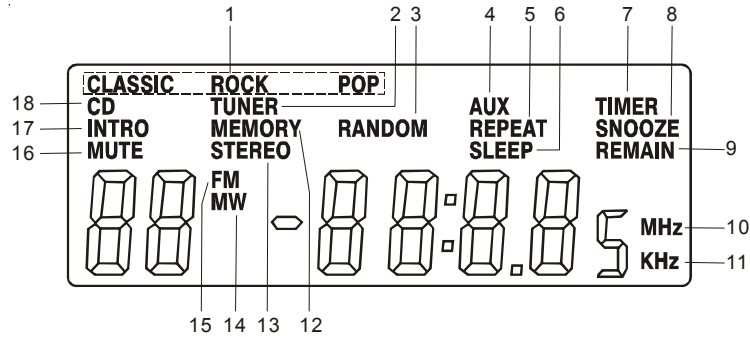

- | | |
|---------------------|----------------------|
| 1. EQ Indicator | 10. MHz Indicator |
| 2. TUNER Indicator | 11. KHz Indicator |
| 3. RANDOM Indicator | 12. MEMORY Indicator |
| 4. AUX Indicator | 13. STEREO Indicator |
| 5. REPEAT Indicator | 14. MW Indicator |
| 6. SLEEP Indicator | 15. FM Indicator |
| 7. TIMER Indicator | 16. MUTE Indicator |
| 8. SNOOZE Indicator | 17. INTRO Indicator |
| 9. REMAIN Indicator | 18. CD Indicator |

Please note that the display can only be viewed from directly opposite and above. This is the design of the unit and not a fault.

REMOTE CONTROL

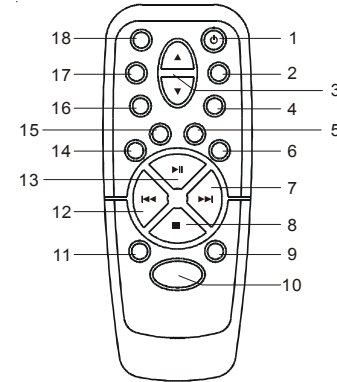

1. POWER Key
2. PRESET EQUALIZER Key (EQ)
3. VOLUME Keys
4. SNOOZE Key
5. INTRO Key
6. REPEAT Key
7. F.F Key
8. STOP / BAND Key
9. MEMORY-UP Key
10. FUNCTION Key
11. DISPLAY Key
12. REW Key
13. PLAY/PAUSE Key
14. MEM/CLOCK Key
15. RAND Key
16. TIMER Key
17. SLEEP Key
18. MUTE Key

CONNECTION

- Do not switch the power to the unit on until all connections are made.
- Unravel and position the FM aerial lead away from the power and speaker cords as these could generate noise. Do not position the FM aerial lead so that it touches the rear of the unit.

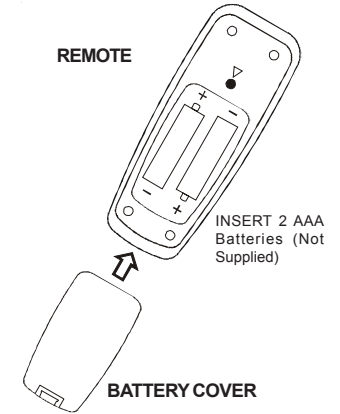

REPLACING THE BATTERY

If the remote control has erratic or does not operate. Replace the batteries (type AAA, obtainable from most shops). Remove the battery cover from the back of the remote. Remove the batteries and insert new batteries observing correct polarity. Replace the battery cover into the remote.

SPEAKER CORD CONNECTION

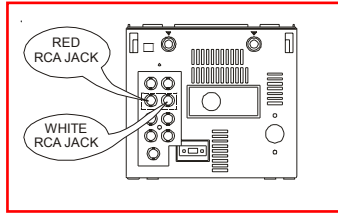

Connect the cable from the speaker on the left to the (L) terminal and the cable from the speaker on the right to the (R) terminal.

DO NOT CONNECT
THE SPEAKERS TO
THE AUX SOCKETS

NOTE:

The speakers are not magnetically shielded. If placed next to or on top of your TV. The picture colour will be distorted. Install the speaker at least 5 inches away from your TV.

AC POWER CONNECTION

Connect the ac power lead after all other connections have been made.

NOTE:

When there is a long power failure, or the mains lead is disconnected for more than 3 hours, the clock and tuner preset stations will be erased from the memory. Reset the clock and presets when power is restored.

SWITCHING THE UNIT ON AND OFF

Press the power button to turn the unit on.

POWER STANDBY

Power standby mode allows you to turn the unit on and off (to standby mode) with the power button on the remote control or on the unit itself. If you want to turn off the unit completely, remove the AC plug from the household mains supply.

VOLUME CONTROL

To adjust the volume, rotate the VOLUME knob on front panel or press the VOLUME DOWN/UP button on remote control until the volume is at the desired level.

STEREO HEADPHONES

Stereo headphones socket is provided on the front panel of the main unit (headphones not supplied). Connect low impedance (4-32ohm) stereo headphones to the headphone socket for private listening. Inserting the 3.5mm headphone jack plug automatically disconnects the loudspeakers.

SETTING THE CLOCK

1. Press DISPLAY/REMAIN unit the clock is shown on the display.
2. Press and hold the MEMORY/CLK-ADJ until `24H` flashes on display. Use UP/FF ►► to select 24 hour format or 12 hour format.
3. Press MEMORY/CLK-ADJ, the hour digit will flash, press UP/FF ►► or DOWN/REW ◀◀ to set the correct hour.
4. Press MEMORY/CLK-ADJ again the minute digit will flash, press the UP/FF ►► or DOWN/REW ◀◀ to set the correct minutes.
5. Press MEMORY/CLK-ADJ again to set the clock.

COMPACT DISCS

1. Always use compact discs bearing the mark as shown:



2. Note: Home recorded discs (CDR) are not guaranteed to work on this player.
3. Notes on handling discs. Removing the disc from its storage case.



- Do not touch the reflective recorded surface.
 - Do not bend the disc.
 - Do not stick or write anything on the surface.
4. Storage
 - Store the disc in its case.
 - Do not expose the disc to direct sunlight, high temperatures, high humidity or dusty places.
 5. Cleaning a disc
 - Should the disc become soiled, wipe off dust, dirt and fingerprints with a soft cloth. The disc should be cleaned from the centre to the edge.

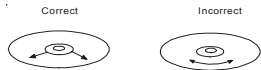

- Never use benzene, thinners, record cleaner fluid or antistatic spray. 8cm (3 3/16) "CD singles" can be used (without using an adapter) in this unit.

CLEANING THE LENS

If the lens in the CD pick-up is dirty, dusty, etc., it could degrade the sound or prevent disc play.

- Use a blower (available from camera stores) to blow dust off the lens.
- If there are fingerprints, etc., on the lens, gently wipe clean with a cotton swab.

NOTE:

Only the discs marked with the disc logo are guaranteed to work on this player. Home recorded discs (CDR) recorded on home pc's may not play or operate correctly. CDRW discs cannot be played.

COMPACT DISC OPERATION

INSERTING THE DISC

1. Press CD key.
2. Press OPEN/CLOSE key to open the CD door.
3. Insert a CD in the tray.
4. Press OPEN/CLOSE key to close the CD door. The CD-player starts and scans the contents list of the CD. After a few seconds, the total playing time and number of tracks will appear on the display.

PLAYING THE ENTIRE DISC

1. Press PLAY/PAUSE ►||.
 - Play starts with the first track.
 - The display shows the current track number and its elapsed playing time.
 - When all the tracks have been played, the CD player stops and the total number of tracks and total playing time are shown on the display.
2. To stop playback, press STOP ■.

3. To pause playback, press PLAY/PAUSE ►||.
4. To resume play, press PLAY/PAUSE ►|| again.

SELECTING TRACKS

Press UP/FF ►► or DOWN/REW ◀◀ until the required track number appears in the display.

SEARCHING FOR A PASSAGE

DURING PLAY press and hold UP/FF ►► or DOWN/REW ◀◀ to search for the required passage. When the button is released, playback will continue. The volume will automatically be reduced to a low level during search operation and will return to its normal level when the search button is released.

PROGRAMMING TRACKS

- Up to 20 tracks can be programmed.
1. Load a CD as described under Inserting the disc.
 2. Press MEMORY/CLK-ADJ to start programming.
 3. Press UP/FF ►► or DOWN/REW ◀◀ to select the desired track. The track number will be displayed on the LCD.
 4. Press MEMORY/CLK-ADJ to store it in the memory.
 5. To stop programming, press STOP ■ once.
 6. The programming will automatically stop if no button is pressed within 10 seconds.

REVIEWING THE PROGRAM

1. Press MEMORY/CLK-ADJ repeatedly to review the tracks currently programmed.

The tracks will be displayed on the LCD.

PLAYING A PROGRAM

1. Press PLAY/PAUSE ►||.
2. Play starts with the first track of the program.
3. When all tracks have been played, the CD player stops.

CLEAR PROGRAM TRACKS

To clear the program press MEMORY/CLK-ADJ and then press stop ■.

RANDOM PLAY

To play all the tracks in a random order.

1. Press CD Key.
2. Press RANDOM Key.
3. "RANDOM" illuminates in the display.
4. Press PLAY/PAUSE.
5. The tracks will be played in a random order.
6. Press STOP or RANDOM to cancel the random mode.

REPEAT PLAY

To listen to a disc or track over and over again.

1. Press M-UP/REPEAT.
2. "REPEAT" will illuminate in the display. The whole disc will be repeated.
3. Press M-UP/REPEAT again, "REPEAT" will flash in the display. The current track will be repeated.
4. Press M-UP/REPEAT until "REPEAT" disappears from display to cancel the repeat function.

DISPLAY FUNCTION

In Radio Mode:

Press DISPLAY/REMAIN to change display information as follows:

Frequency display > Clock display > Timer ON time (Frequency display)

In CD Mode:

Press DISPLAY/REMAIN to change display information as follows: Elapsed time > remaining time > Clock display > Timer ON time (CD normal display)

- Random Play:

Elapsed time remaining time > Clock display > Timer ON time

- Memory Play:

Elapsed time remaining time > Remain > Clock display > Timer ON time.

In Other Mode:

Press MODE/REMAIN to change display information as follows:
Clock display > Timer ON (Clock display)

Important note:

Please ensure that small children/babies do not operate this appliance. Keep them away from the motorized CD tray as trapped fingers may hurt.

TUNER OPERATION

TUNING

1. Press POWER to switch on the unit.
2. Press "TUNER" button to select tuner.
3. Select the required waveband by pressing the STOP/BAND button.
4. Press UP/FF ►► or DOWN/REW ◀◀ for few seconds, then release.
 - The tuner will automatically search for the first transmitter of sufficient strength.
 - Repeat this procedure if you wish to select another station.
5. To tune to weak stations, briefly press UP/FF ►► or DOWN/ REW ◀◀ repeatedly until the correct frequency is found.
6. If there is a large amount of interference(noise)move the STEREO/MONO switch to the mono position.

PROGRAMMING OF PRESET STATIONS

1. Press "TUNER" button to select tuner.
2. Tune to the desired station as described under Tuning.
3. Press PROG/MEM(on remote). "MEMORY" will start to flash and channel "00" will displayed.
4. Press M-up to assign a number (1-10) to the preset station.
5. Press PROG/MEM (on remote) again. The frequency, and preset number are now entered in the memory.

6. Repeat this procedure to store other frequencies and preset in the memory.

TUNING TO PRESET STATIONS

Select a number between 1 and 10 by pressing: M-UP/REPEAT button.

TIMER OPERATION

Before setting the timer, make sure the clock is correctly set.

TIMER ON SETTING

Press CD, TUNER to select the desired sound source.

Please note when the timer turns on the unit, the source will be the same as the last source listened to before turning off the system.

For TUNER

1. Select TUNER, press M-UP/ REPEAT to select a preset station.
2. The display will show the selected preset station and frequency.
3. Press TIMER on the remote or press and hold SLEEP/TIMER on main unit timer appears on display.
4. Press and hold PROG/MEM on the remote or MEMORY/CLOCK-ADJ on the main unit until the hour digit starts to flash.
5. Press the UP/FF ►► or DOWN REW ◄◄ to set the hour.
6. Press PROG/MEM or MEMORY/ CLOCK-ADJ again.
7. Use UP/FF ►► or DOWN REW ◄◄ to set minutes.
8. Press PROG/MEM or MEMORY/ CLOCK-ADJ to set timer.

For CD

1. Insert a disc into the CD tray.
2. Press TIMER.
3. Follow steps 3 to 8 under tuner timer setting.

To cancel the Timer press the Timer Button on the Remote.

SLEEP

1. Press SLEEP, 'SLEEP' appears on the display.
2. Keep pressing SLEEP to adjust the sleep time in the order of 90>80>70....10 minutes.
3. To cancel the SLEEP mode, press SLEEP again.

PRESET EQUALIZER

Press PRESET EQ to add a digital sound effect to the audio output.

MUTE

Press MUTE to mute the sound output. Press again to cancel this mode.

CONNECTING AN EXTERNAL AUDIO SOURCE

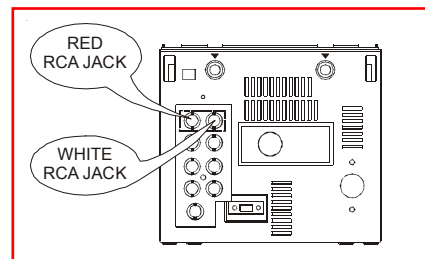

AUX input can be used to connect external equipment (e.g. TV or VCR) to this system connect as shown below.

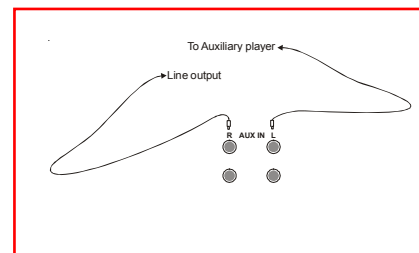

TROUBLESHOOTING GUIDE

Please make these simple checks before calling our helpline. These tips can save you time and money.

NO POWER

- Make sure the power cord is inserted fully into a 230V/50Hz outlet.
- Check that the outlet is not controlled by a wall switch.
- Unplug the power cord, wait 1 minute, then reinsert the plug and push the POWER button.

NO VOLUME

- Check the VOLUME control setting.
- Make sure the correct feature has been selected. (For instance, "CD" should be selected when playing a CD.)
- Make sure the speakers are properly connected.
- Make sure the speaker wires are not shorted together.
- If headphones are plugged in, disconnect them.

REMOTE CONTROL DOES NOT WORK

- Check and if necessary, replace the batteries.
- Make sure the remote emitter is pointed at the micro system.
- The remote may be too far away from micro system.

CAN'T TUNE RADIO STATIONS

- Repeat channel selection.
- Make sure the FM wire aerial is unravalled & fully extended

NOTE: If operation of the unit or display is not normal, you should reset the unit by disconnecting it from the household wall outlet for 1 minute and then reinsert the plug.

WARNING: IF ANY OF THE ABOVE HINTS DOES NOT SOLVE THE PROBLEM YOU ARE EXPERIENCING, PLEASE CALL OUR PRODUCT INFORMATION HELPLINE FOR FURTHER ASSISTANCE.

TECHNICAL SPECIFICATIONS

Power Supply : AC power
Output Power (Per Channel): 12.5 watts RMS into 4 ohm
Power Consumption : 28W

Radio Section
Frequency Range : AM 522 - 1620 KHz
FM 87.5 - 108 MHz

Compact Disc Section
Frequency Response (-6dB): 20-15,000 Hz
Signal-to-noise Ratio : 50 dB
Harmonic Distortion : 0.4%
Channel Separation : 40 dB

CONTINUOUS IMPROVEMENTS ARE BEING MADE TO OUR EQUIPMENT BOTH IN QUALITY AND PERFORMANCE, THUS WE RESERVE THE RIGHT TO ALTER SPECIFICATIONS WITHOUT NOTICE.